

Radial-Werkzeughalter Form B4 Überkopf links, kurz

Radial toolholders form B4 overhead left, short

Porte-outils radials forme B4 inversés gauche, court

DIN ISO 10889-1
(DIN 69880)



Verwendung:
Vorwiegend für Außenbearbeitung.
Zum Plan Einstechen.

Application:
Mainly for external machining.
For face machining.

Application:
Principalement pour usinage extérieur.
Pour carottage.

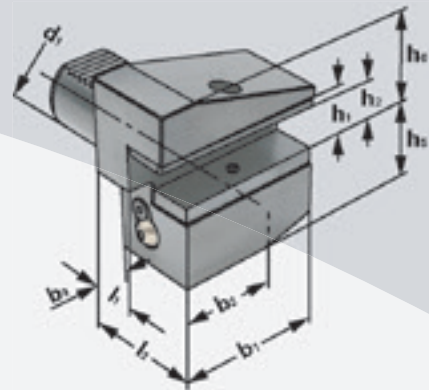

DIN ISO 10889
(DIN 69880)

B4

Bestell-Nr. Order no. Référence	Abmessung Size Dimension	d ₁	h ₁	h ₂	l ₂	l ₁	b ₁	b ₂	b ₃	h ₅	h ₆
169.34.12	B4 – 16 × 12 × 24	16	12	–	24	13	42	23	5	20	22
209.34.16	B4 – 20 × 16 × 30	20	16	12	30	16	55	30	7	35	30
259.34.16	B4 – 25 × 16 × 30	25	16	12	30	16	55	30	7	35	30
309.34.20	B4 – 30 × 20 × 40	30	20	16	40	22	70	35	10	35	38
409.34.25	B4 – 40 × 25 × 44	40	25	20	44	22	85	42,5	12,5	42,5	48
509.34.32	B4 – 50 × 32 × 55	50	32	25	55	30	100	50	16	50	60

Ausführung: Mit einstellbarer Kugelspritzdüse und Unterlegplatte
Version: With adjustable spray nozzle and shim
Version: Avec gicleur ajustable et semelle

